

Assembly Instruction

Model : PLM 4300

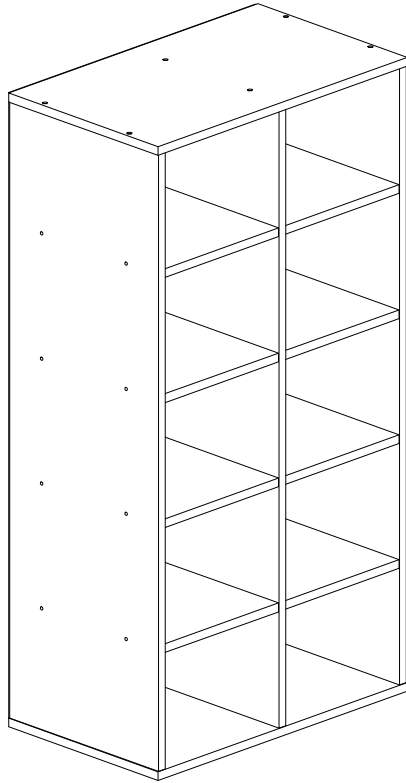

Hardware List			
No.	SHAPE	DESCRIPTION	Qty.
A		8x25mm Dowel (Wood)	44Pcs
B		M4x45mm Screw	28Pcs
C		5/8 Nail With Pin	4Pcs
D		6/8 Power Pin	30Pcs
E		Sticker	22Pcs

Part List

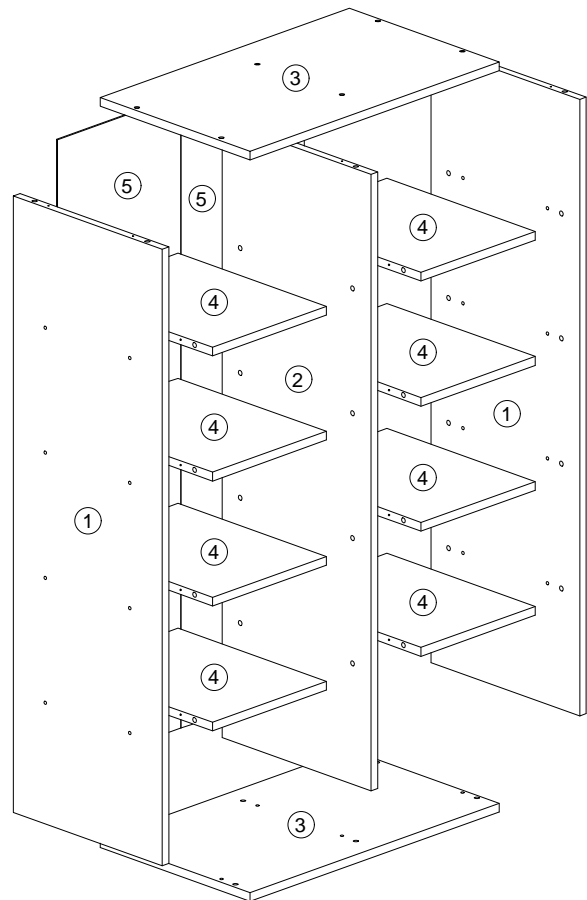

Assembly Instruction

Step 1

A		8x25mm Dowel (Wood)	44Pcs
---	--	---------------------	-------

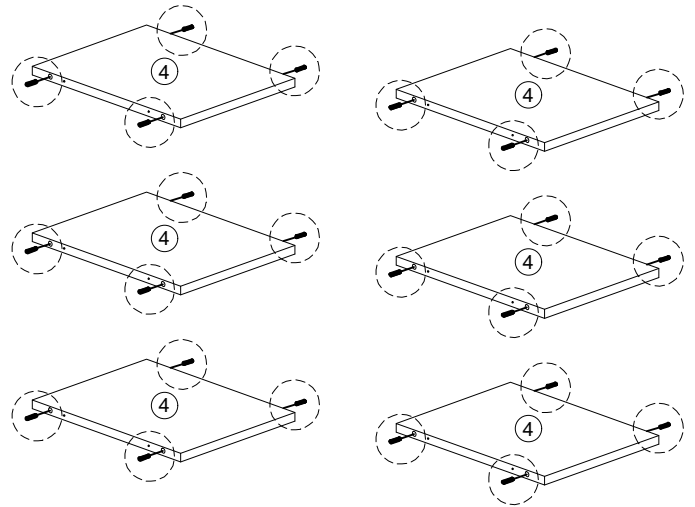
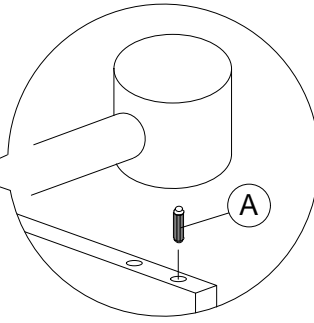
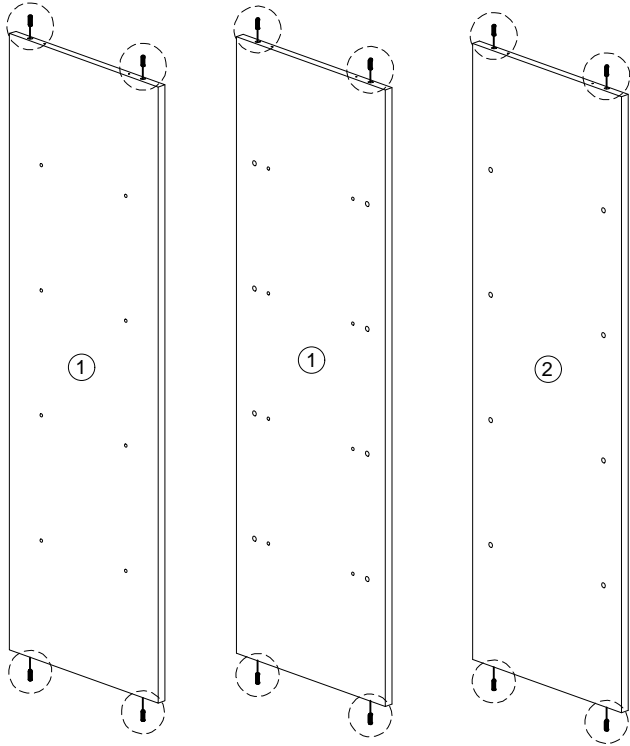

Step 2

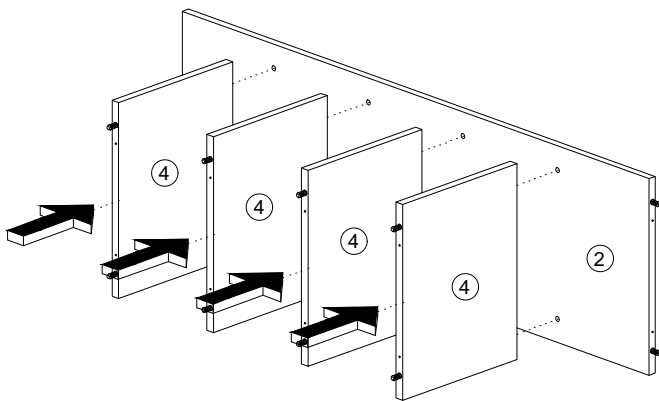

Step 3

B		M4x45mm Screw	8Pcs
E		Sticker	8Pcs

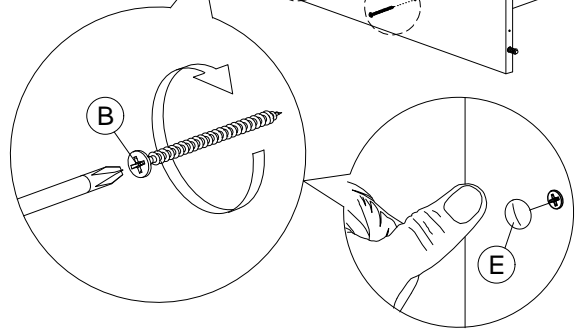
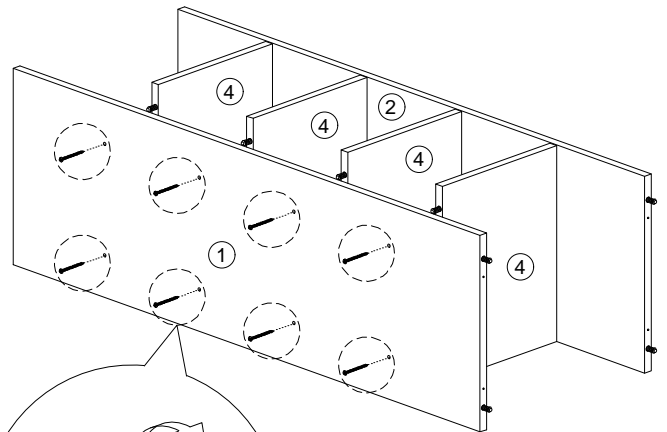

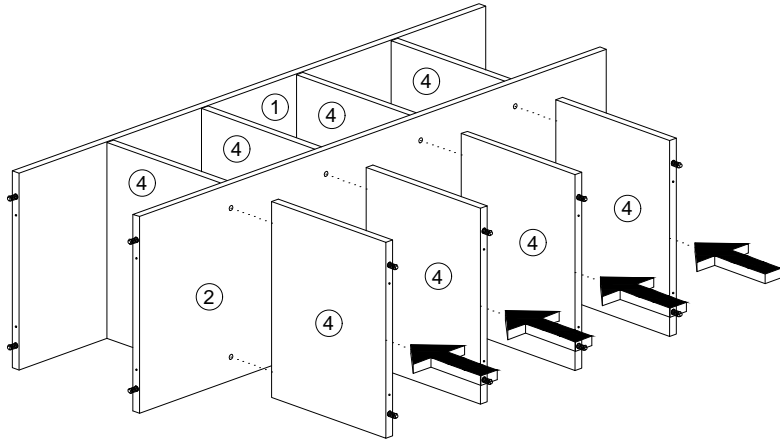

Assembly Instruction

Step 4



Step 5

B		M4x45mm Screw	8Pcs
---	---	---------------	------

E		Sticker	8Pcs
---	---	---------	------

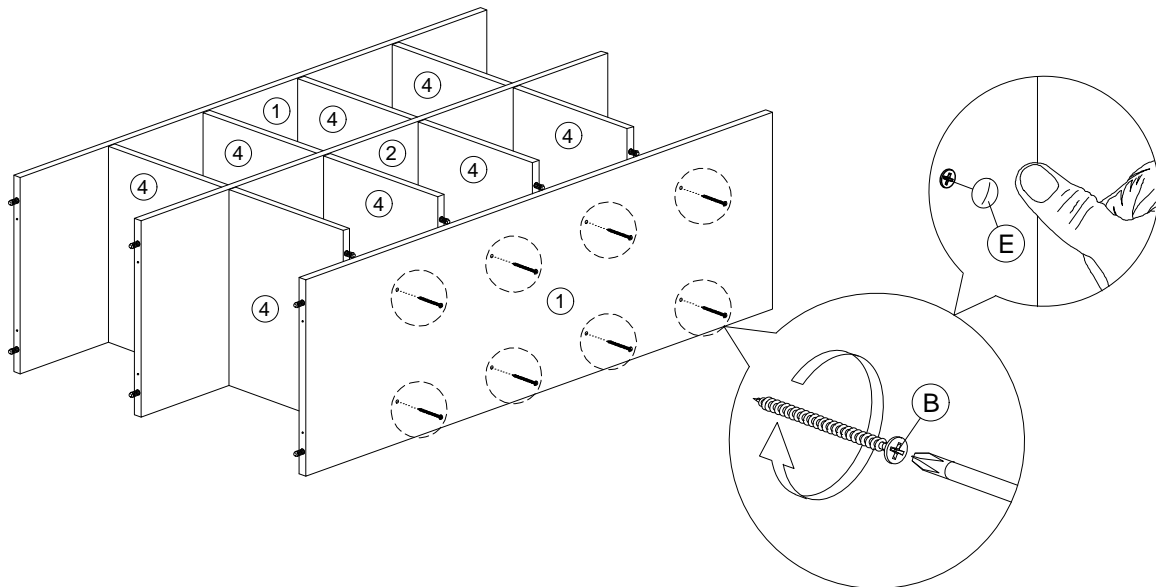

Assembly Instruction

Step 6

B		M4x45mm Screw	6Pcs
---	---	---------------	------

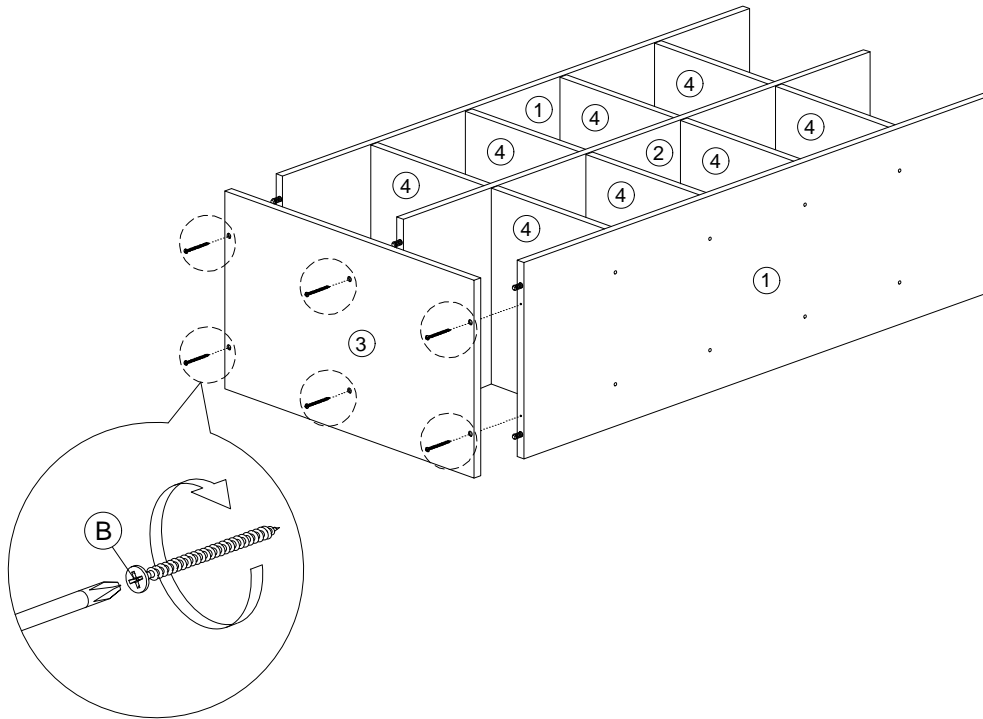

Step 7

C		5/8 Nail With Pin	4Pcs
---	---	-------------------	------

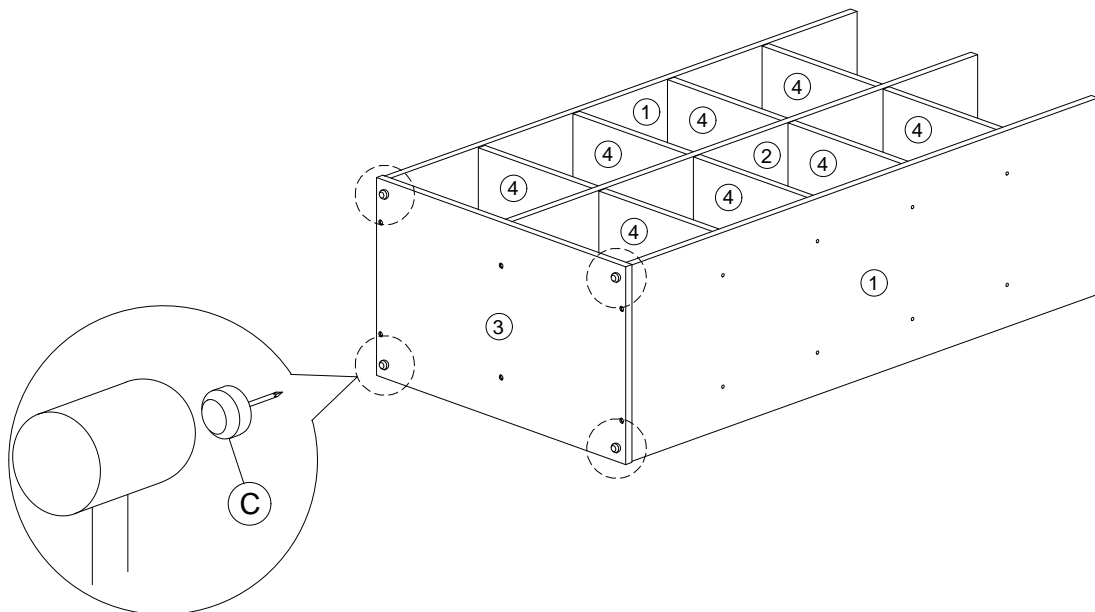

Assembly Instruction

Step 8

B		M4x45mm Screw	6Pcs
---	---	---------------	------

E		Sticker	6Pcs
---	---	---------	------

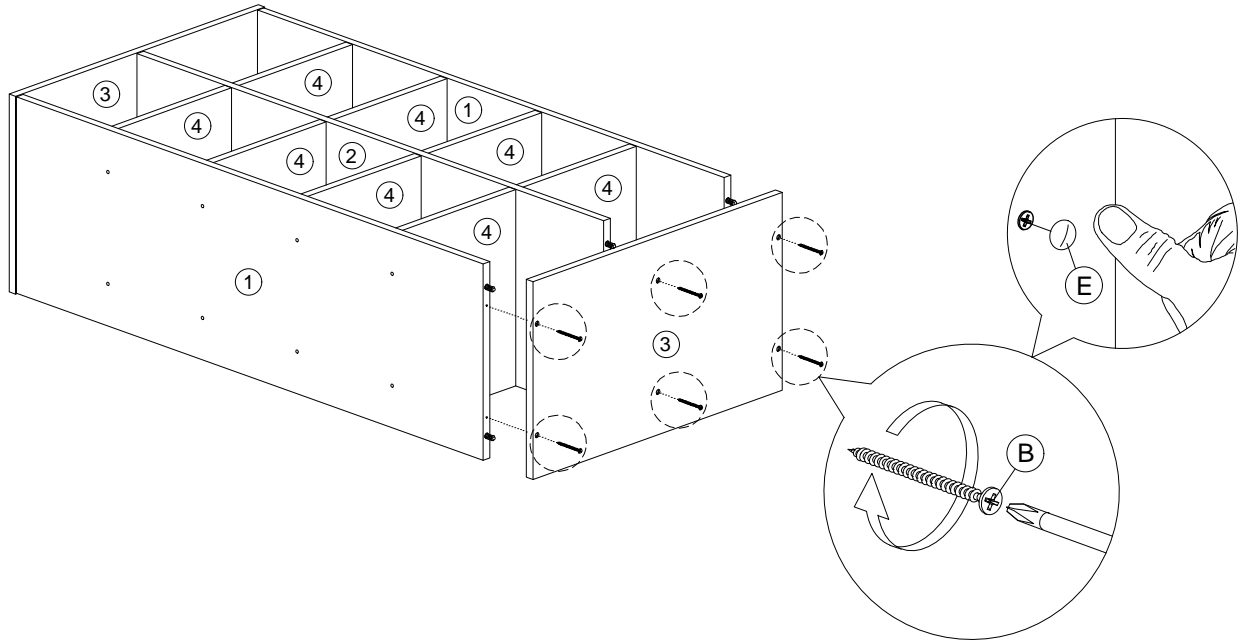

Step 9

D		6/8 Power Pin	30Pcs
---	---	---------------	-------

